

SELECT MkII

MOULDED ACRYLIC INSET BATHS

FEATURES

- Rectangular inset bath in durable sanitary-grade acrylic material
- Comfortable shape with good lumbar support plus arm rests.
- Two standard sizes to suit most installations plus a larger 'twin' model
- Slip-resistant bath floor, twin soap recesses
- Integrated tiling lip on all edges
- Integrated self-supporting base for easy installation

SIZE	CODE:
Select MkII 1520	J5152
Select MkII 1660	J5166
Select MkII 1800	J5180

MODELS

L x W x H

Select MkII bath	1520 x 750 x 420	J5152
	1660 x 750 x 420	J5166
	1800 x 800 x 480	J5180

OPTIONAL

40mm plug and waste	PW3
---------------------	-----

WARRANTY

Acrylic baths 15 year replacement
-refer to T&Cs at www.johnsonsuisse.com.au



J5152/J5166



J5180

PRODUCT DIMENSIONS

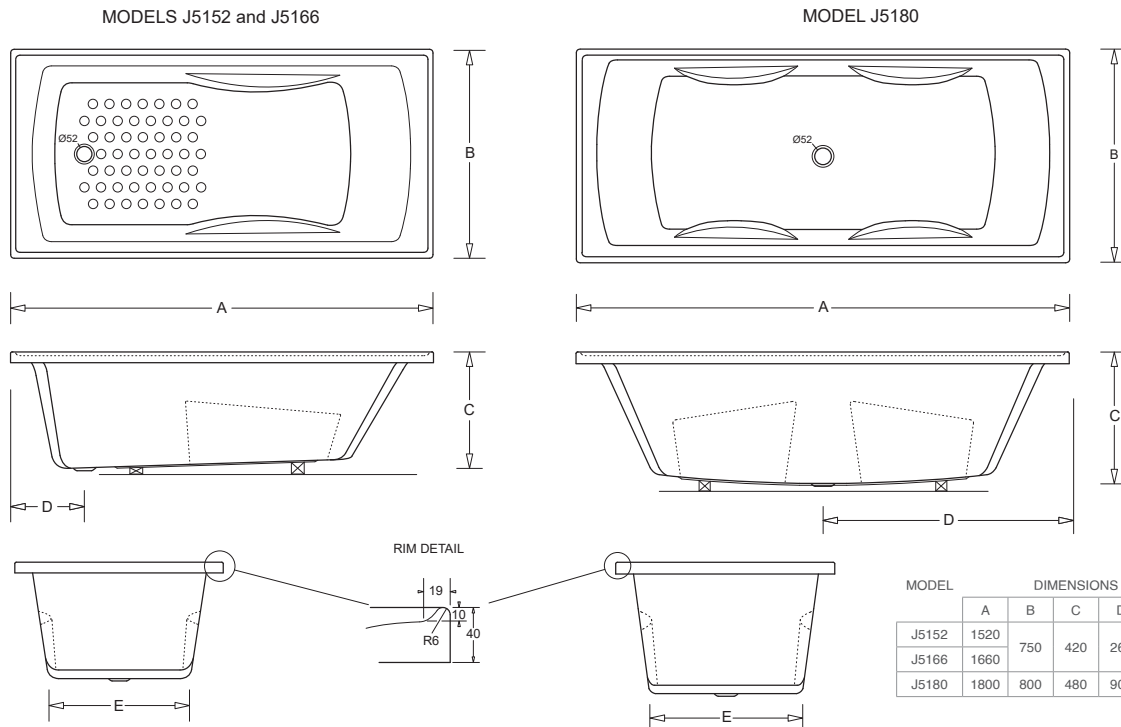

MODEL	DIMENSIONS					WEIGHT Kg	CAPACITY L
	A	B	C	D	E		
J5152	1520	750	420	265	512	15-19	175
J5166	1660					15-19	210
J5180	1800	800	480	900	560	20-24	280

TECHNICAL DATA SHEET

SUPERSEDES ALL PREVIOUS ISSUES

All dimensions are in millimetres and are subject to normal manufacturing variation.
As product development is ongoing BPA reserves the right to vary specifications without notice.
Bathroom Products Australia Pty Ltd ABN 87 079 297 617